

**Repair instruction
and
Spare parts lists
for**

NOVOpress

POWER PACKS

HA1ES / HA2 / HA1ES-BAU

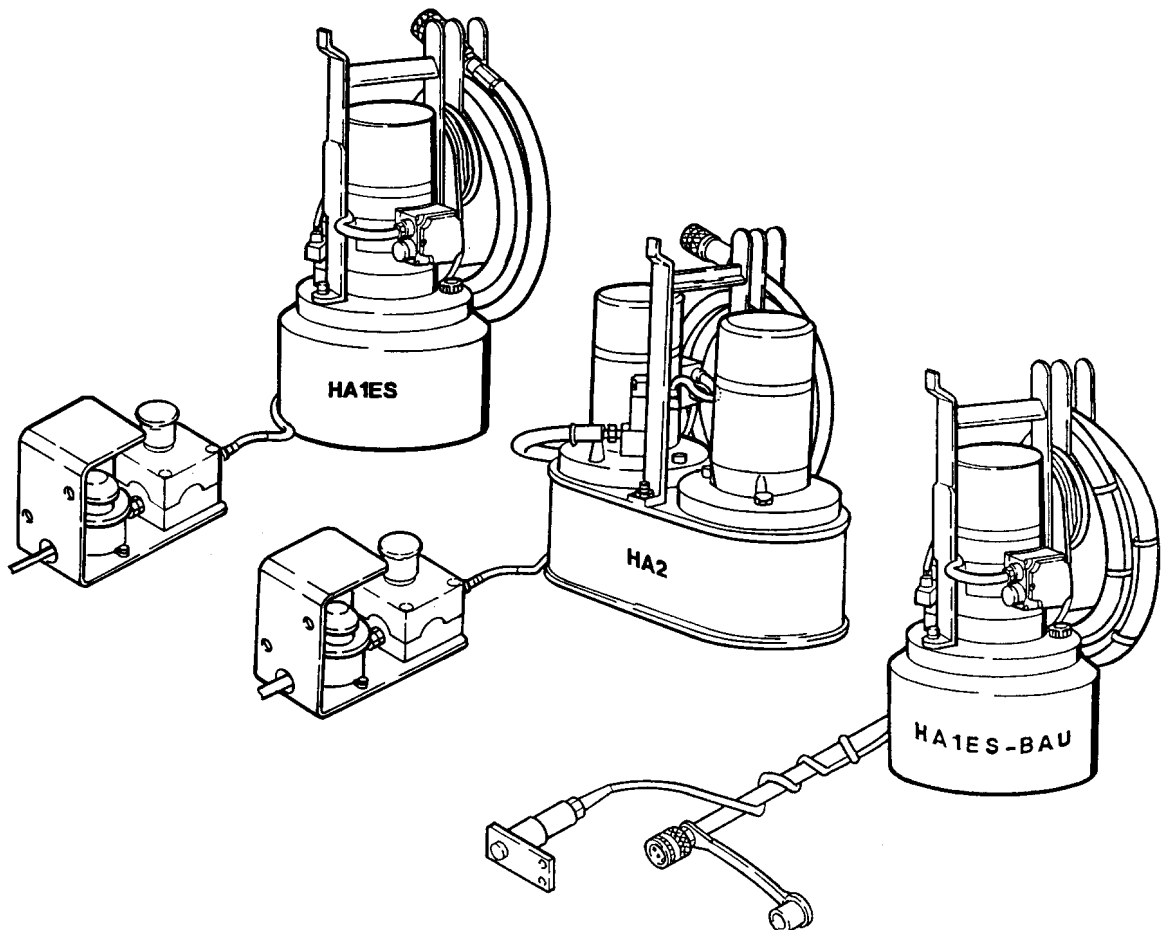

A. Operating troubles and their remedy

Item	Failures	Cause	Remedy
1	Implement piston does not ascend or does not fully ascend	a. Oil-level too high b. Electromagnet, Item 7 (6775), does not work c. Electromagnet, Item 7 (6775), soiled d. Valve, Item 2 (6420), soiled	Refill with oil Check electric supplies Loosen plug , Item 8 (6775) from electromagnet , valve, Item 7 (6775). Unscrew 4 screws, Item 9 (6775). Take off electromagnet, clean, use only hydraulic oil for cleaning. Proceed as described under Items 3.1 to 3.4 of repair instructions. Unscrew valve chamber, Item 1, from sealing bushing, Item 2. CAUTION: Parts are under spring tension! Dismantle and clean parts, Item 3 to 9 (6776), rinse valve housing, Item 1 (6776).
2	Implement piston ascends very slowly and does not achieve full performance	a. Suction sieve, Item 14, soiled b. Safety valve, Item 10, soiled and does not close properly from valve body, Item 1 (4266).	Proceed as described under Item 4.1 to 4.2 of the repair instructions. Clean sieve disk, Item 5 (1302). Proceed as described under Items 2.1 to 2.3 of the repair instructions. Unscrew adapter, Item 3 (4266), CAUTION: Parts are under spring tension! Take out and clean parts, Item 2 to 7 (4266). During assembly of the valve take care that absolutely, the same number of insert disks. Item 6 to 7 (4266), is installed, as turn-off pressure would otherwise be altered. The flat countersink of the safety valve must point towards the gear pump during mounting. Install insert disks 1x0,5 mm and 1x1 mm thick. supplied with in the oil tank, into the valve body. Item 1 (4266), according to requirements! + 1 mm insert geight = + 10 bar
3	Implement piston does not descend	Valve, Item 2 (6420) soiled	cf. Item 1.d

ADVICE!

Item 7 (6775) signifies
 Item 7
 Subassembly-No 6775

here elektromagnet
 here connection block, complete

CAUTION!

Pull out mains plug prior to the start of maintenance work.

In the case of repairs on electric motors, the high-voltage tests in accordance with VDE 0740^{*1} and CEE^{*2} Publication 20 have to be carried out.

*1 VDE - Verein Deutscher Ingenieure - Association of German Engineers

*2 CEE - Communauté Economique Européenne - European Community

3900 Power pack HA1ES with electric motor (from pack No. 5609)

3900 Power pack HA1ES with electric motor (from pack No. 5609)

Item	Description	Order No.	Quantity
1	Oil reservoir	1073	1
2	Oil tank cover	1561	1
3	Electric motor	4296	1
4	Socket head screw	11010	4
5	Washer	11231	4
6	Coupling	1709	1
7	O-ring	11006	1
8	Gear pump	4298	1
9	Socket head screw	11009	2
10	Safety valve	4266	1
11	Solenoid valve	6420	1
12	Hydraulik pipe	6206	1
13	Fitting	1410	1
14	Suction sieve	1302	1
15	Vent valve	1532	1
16	O-ring	11001	1
17	O-ring	11007	2
18	Handle	3815	1
19	Socket head screw	11006	2
20	Hydraulik hose	4302	1
21	Coupling sleeve	3719	1
23	Welch plug	11023	1
24	Connecting cable	11026	1
29	Foot-/emergency-stop-switch	9186	1
32	Dust cap	1515	1
503	Packing set for coupling HA	1648	1
510	Packing set HA1ES from unit No. 3567	12351	1

ATTENTION!

For all orders regarding electromotors,
indicate the voltage beside the ref. no.
For example: electromotor 4296/110V

For all orders regarding electromagnetis valves,
please name frequency and voltage beside the ref.no.
For example: solenoid valve 6420/110V/60Hz

3900-11 Power pack HA1ES with electric motor (to pack No. 5608)

3900-11 Power pack HA1ES with electric motor (to pack No. 5608)

Item	Description	Order No.	Quantity
1	Oil reservoir	1073	1
2	Oil tank cover	1561	1
3	Electric motor	4296	1
4	Socket head screw	11010	4
5	Washer	11231	4
6	Coupling	1709	1
7	O-ring	11006	1
8	Gear pump	4298	1
9	Socket head screw	11009	2
10	Safety valve	4266	1
11	Solenoid valve	6420	1
12	Hydraulik pipe	6206	1
13	Fitting	1410	1
14	Suction sieve	1302	1
15	Vent valve	1532	1
16	O-ring	11001	1
17	O-ring	11007	2
18	Handle	3815	1
19	Socket head screw	11006	2
20	Hydraulik hose	4302	1
21	Coupling sleeve	3719	1
23	Welch plug	11023	1
24	Connecting cable	11026	1
29	Cable	12558	1
27	Connecting cable	4297	1
28	Guard bow	2180	1
29	Foot switch	11020	1
30	Spring washer	11038	2
31	Socket head screw	11081	2
32	Dust cap	1515	1
503	Packing set for coupling HA	1648	1
504	Packing set for HA1ES up to unit No. 3566	11585	1
505	Packing set HA1ES from unit No. 3567	12351	1

ATTENTION!

For all orders regarding electromotors,
indicate the voltage beside the ref. no.
For example: electromotor 4296/110V

For all orders regarding electromagnetis valves,
please name frequency and voltage beside the ref.no.
For example: solenoid valve 6420/110V/60Hz

4200 Power pack HA2 with 2 electric motors (from pack No. 570)

4200 Power pack HA2 with 2 electric motors (from pack No. 570)

Item	Description	Order No.	Quantity
1	Oil reservoir	4205	1
2	Oil tank cover	1561	2
3	Electric motor	4296	2
4	Socket head screw	11010	8
5	Washer	11231	8
6	Coupling	1709	2
7	O-ring	11006	2
8	Gear pump	4298	2
9	Cylinder screw	11009	4
10	Safety valve	4266	1
11	Solenoid valve	6420	1
12	Hydraulik pipe	6225	1
13	Elbow	1410	2
14	Suction sieve	1302	2
15	Vent valve	1532	2
16	O-ring	11001	2
17	O-ring	11007	4
18	Handle	3815	1
19	Socket head screw	11085	4
20	Hydraulic hose	4302	1
21	Coupling sleeve	3719	1
23	Strain relief	11023	2
24	Connecting cable	11026	1
25	Connecting cable	12559	1
29	Foot-/emergency-stop-switch	9186	1
32	T-screw connection	11090	1
33	Angular screw connection	11091	1
34	HD (heavy duty) hose pipe	11092	1
35	Washer	11174	4
36	Socket head screw	11086	2
37	Power connection pipe	6224	1
38	Hexagon screw nut	11017	2
39	Socket head screw	11087	1
40	Dust cap	1515	1
43	Angular fitting	11212	1
503	Packing set for coupling HA	1648	1
510	Packing set HA2 basic appliance from unit No. 327	12352	1

ATTENTION!

For all orders regarding electromotors,
indicate the voltage beside the ref. no.
For example: electromotor 4296/110V

For all orders regarding electromagnetis valves
please name frequency and voltage beside the ref.no..
For example: Solenoid valve 6420/110V/60Hz

4200-11 Power pack HA2 with 2 electric motors (to pack No. 569)

4200-11 Power pack HA2 with 2 electric motors (to pack No. 569)

Item	Description	Order No.	Quantity
1	Oil reservoir	4205	1
2	Oil tank cover	1561	2
3	Electric motor	4296	2
4	Socket head screw	11010	8
5	Washer	11231	8
6	Coupling	1709	2
7	O-ring	11006	2
8	Gear pump	4298	2
9	Cylinder screw	11009	4
10	Safety valve	4266	1
11	Solenoid valve	6420	1
12	Hydraulik pipe	6225	1
13	Elbow	1410	2
14	Suction sieve	1302	2
15	Vent valve	1532	2
16	O-ring	11001	2
17	O-ring	11007	4
18	Handle	3815	1
19	Socket head screw	11085	4
20	Hydraulic hose	4302	1
21	Coupling sleeve	3719	1
23	Strain relief	11023	2
24	Connecting cable	11026	1
25	Connecting cable	12559	1
26	Cable	12558	1
27	Connecting cable	4297	1
28	Guard	2180	1
29	Foot switch	11020	1
30	Spring washer	11038	2
31	Socket head screw	11081	2
32	T-screw connection	11090	1
33	Angular screw connection	11091	1
34	HD (heavy duty) hose pipe	11092	1
35	Washer	11174	4
36	Socket head screw	11086	2
37	Power connection pipe	6224	1
38	Hexagon screw nut	11017	2
39	Socket head screw	11087	1
40	Dust cap	1515	1
43	Angular fitting	11212	1
503	Packing set for coupling HA	1648	1
504	Packing set for HA2 basic appliance up to unit No 326	11586	1
510	Packing set HA2 basic appliance from unit No 327	12352	1

ATTENTION!

For all orders regarding electromotors,
indicate the voltage beside the ref. no.
For example: electromotor 4296/110V

For all orders regarding electromagnetis valves
please name frequency and voltage beside the ref.no..
For example: Solenoid valve 6420/110V/60Hz

4350 Power pack HA1 - ES Bau

4350 Power pack HA1 - ES Bau

Item	Description	Order No.	Quantity
1	Oil tank	1073	1
2	Oil tank cover	1561	1
3	Drive motor	4296	1
4	Socket head bolt	11010	4
5	Washer	11231	4
6	Coupling	1709	1
7	O-ring	11006	1
8	Gear pump	4298	1
9	Socket head bolt	11009	2
10	Safety valve	4266	1
11	Solenoid valve	6420	1
12	Pressure pipe	6206	1
13	Fitting	1410	1
14	Suction filter	1302	1
15	Breather	1532	1
16	O-ring	11001	1
17	O-ring	11007	2
18	Handle	3815	1
19	Socket head screw	11008	2
24	Mains cable	11026	1
25	Insulated cable	11021	1
27	Cable	12159	1
32	Handle with integrated switch	1956	1
35	Angular fitting	11212	1
503	Packing set for coupling HA	1648	1
504	Packing set for HA1ES up to unit No 3566	11585	1
505	Packing set HA1ES from unit No 3567	12351	1

ATTENTION!

For all orders regarding electromotors,
indicate the voltage beside the ref.no.
For example: electromotor 4296/110V

For all orders regarding electromagnetis valves,
please name frequency and voltage beside the ref.no.
For example: Solenoid valve 6420/110V/60Hz

C. REPAIR INSTRUCTIONS SUBASSEMBLIES

1. Exchange coupling, Item 6, Order No. 1709

-PULL OUT MAINS PLUG-

- 1.1 Unscrew two screw, Item 19.
- 1.2 Take handle, Item 18, off power pack 3900 HA1ES/4350 HA1ES-BAU
Not necessary for power pack 4200 HA2.
- 1.3 Take off the oil tank lid, Item 2, complete with electric motor, Item 3, from oil tank, Item 1.
- 1.4 Unscrew four screw, Item 4.
- 1.5 Take off electric motor, Item 3, from oil tank lid, Item 2.
- 1.6 Loosen power connection pipe, Item 12, inbetween solenoid valve,
Item 11, and safety valve, Item 10.
- 1.7 Unscrew hexagon banjo bolt, on safety valve, Item 10.
- 1.8 Pivot safety valve, Item 10, aside.
- 1.9 Unscrew two screws, Item 9, and take off gear pump, Item 8.
- 1.10 Exchange coupling, Item 6.

2. Exchange gear pump, Item 8, Order No. 4298.

-PULL OUT MAINS PLUG-

- 2.1 Proceed as described under Item 1.1 to 1.3 and 1.6 to 1.9.
- 2.2 Take off gear pump, Item 8.
- 2.3 Unscrew gear wheel, Item 1 (1709) from gear pump.
- 2.4 Unscrew suction sieve, Item 14, and fitting, Item 13, from gear pump.
- 2.5 Exchange gear pump, Item 8.

3. Exchange safety valve, Item 10, Order No. 4266

-PULL OUT MAINS PLUG-

- 3.1 Proceed as described under Items 1.1 to 1.3.
- 3.2 Loosen power connection pipe, Item 12, inbetween solenoid valve, Item 11,
and safety valve, Item 10.
- 3.3 Unscrew hexagon banjo bolt, SW14, from safety valve, Item 10.
- 3.4 Exchange safety valve, Item 10.
- 3.5 During assembly of the safety valve, Item 10, the flat countersink must point
towards the gear pump.

4. Exchange solenoid valve, Item 11, Order No. 6420.

-PULL OUT MAINS PLUG-

- 4.1 Proceed as described under Item 1.1 to 1.3 and 1.6 to 1.7.
- 4.2 Unscrew valve, Item 2 (6420), SW24, from connection block, Item 1 (6420).
- 4.3 Unscrew hexagon nut, Item 6 (6775), SW22.
- 4.4 Unscrew slotted screw on plug, Item 8 (6775).
- 4.5 Pull off plug, Item 8 (6775).
- 4.6 Exchange solenoid valve, Item 11.

4.7 Observe following sequence during assembly of the solenoid valve:

- a) Screw connection block, Item 1 (6775), on to oil tank lid, Item 2.
- b) Screw-on valve, Item 2 (6420).
- c) Stick up valve lifter, Item 3 (6420), with sleeve, Item 3 (6775).
- d) Grease slip-on socket, Item 2 (6775) and stick on to solenoid, Item 7 (6775).
- e) Screw on solenoid, Item 7 (6775) with 4 screws, Item 9 (6775).

5. Exchange suction sieve, Item 14, Order No. 1302.

-PULL OUT MAINS PLUG-

- 5.1 Proceed as described under Items 1.1 to 1.3.
- 5.2 Unscrew hexagon banjo bolt, Item 1 (1302), SW14.
- 5.3 Exchange suction sieve, Item 14.

6. Exchange vent valve, Item 15, Order No. 1532.

-PULL OUT MAINS PLUG-

- 6.1 Unscrew sealing screw, Item 1 (1532).
- 6.2 Exchange vent valve, Item 15.
- 6.3 During assembly of the vent valve, screw in the sealing screw only by hand, without a tool - otherwise thread fracture in the lid!

7. Exchange foot switch, Order No. 11020 (HA1 to pack-No. 5608; HA2 to pack No. 569)

-PULL OUT MAINS PLUG-

- 7.1 Unscrew two screws, Item 31.
- 7.2 Unscrew two screws, Item 10 (11020).
- 7.3 Open foot switch, Item 29.
- 7.4 Loosen connection cable, Item 27 and Item 26, from circuit element, Item 8 (11020).
- 7.5 Loosen seal-cable screw connection, Item 14, from connection cable and cast-iron case, Item 1 (11020).
- 7.6 Exchange foot switch, Item 29.

8. Exchange foot switch, Order No. 13311 (HA1 from pack-No. 5609; HA2 from pack No. 570)
(see figure 9186, page 22)

-PULL OUT MAINS PLUG-

- 8.1 Unscrew two screws, Item 4.
- 8.2 Loosen the 4 countersunk head screws from the emergency-stop switch.
Lift cover.
Unscrew two screws, Item 8.
- 8.3 Unscrew two screws, Item 10 (13311).
- 8.4 Open foot switch. item 2.
- 8.5 Loosen connection cable, Item 5 and Item 9, from circuit element, Item 8 (13311).
- 8.6 Loosen cable screw connection, Item 14 and 16 (13311) from connection cable and cast-iron case, Item 1 (13311).
- 8.7 Exchange foot switch, Item 2.

9. Exchange emergency-stop-switch, Order No. 13310 (HA1 from pack No. 5609; HA2 from pack No. 570)
(see figure 9186, page 22)

-PULL OUT MAINS PLUG-

- 9.1 Loosen the 4 countersunk head screws from the emergency-stop switch.
Lift cover.
Unscrew two screws, Item 8.
- 9.2 Unscrew two screws, Item 4 on the foot switch item 2.
- 9.3 Loosen connection cable, Item 1 and Item 5, from circuit element, Item 3 (13310).
- 9.4 Loosen cable screw connection, Item 2 and 3 from connection cable and cast-iron case, Item 1 (13310).
- 9.5 Exchange emergency-stop-switch, item 6.

10. Exchange clamping box, Item 512, Order No. 11902. located on the electric motor -4296-

-PULL OUT MAINS PLUG-

- 10.1 Loosen cover, Item 2 (11994) for clamping box.
- 10.2 Loosen connection cable, Item 26 and Item 24, from terminal board, Item 3 (11902).
- 10.3 Loosen connection cable, Item 26 and Item 24, from strain relief on the clamping box.
- 10.4 Exchange clamping box, Item 512.

11. Exchange electric motor, Item 3, Order No. 4296.

-PULL OUT MAINS PLUG-

- 11.1 Proceed as described under the Items 1.1 to 1.5.
- 11.2 Exchange electric motor, Item 3.

D. SPARE PARTS LISTS / REPAIR INSTRUCTIONS, SINGLE PARTS**4266 Safety valve**

Item	Description	Order No.	Quantity
1	Valve body	3904	1
2	Valve cone, complete	6223	1
3	Adapter	3930	1
4	Pressure spring	3932	1
5	Banjo bolt	3933	1
6	Disk	4378	3
7	Shim-ring	4942	2
8	Usit-ring	11013	2

1. Exchange valve cone, Item 2, Order No. 6223.

1.1 Unscrew adapter, Item 3, SW27, from valve body, Item 1, SW27.

ATTENTION: Parts are under spring tension!

1.2 Exchange valve cone, Item 2.

1.3 During assembly of the valve, take care that absolutely the same number of insert disks, Items 6 and 7, are installed, as turn-off pressure would otherwise be altered.

6420 Solenoid valve

Item	Description	Order No.	Quantity
1	Connection block compl.	6775	1
2	Valve complet	6776	1
3	Valve lifter compl.	6222	1

ATTENTION!

For all orders regarding connecting block or electromagnets, please name not only the ref.no. but the voltage and the frequency, too.

For example: connection block complete 6775/110V/60Hz
 electromagnet 11002/220V/50Hz

6775 Connection block, complete

Item	Description	Order No.	Quantity
1	Connection block	3898	1
2	Slip-on socket	3869	1
3	Bushing	4269	1
4	O-ring	11006	1
5	Screwed connection	11014	1
6	Hexagon screw nut	11017	1
7	Electromagnet	11002	1
8	Plug	11003	1
9	Cheese head	12186	4
10	Straight screwed connection	11027	1
11	O-ring	11005	1

ATTENTION!

For all orders regarding connecting block or electromagnets, please name not only the ref.no. but the voltage and the frequency, too.

For example:

connection block complet 6775/110V/60Hz
 electromagnet 11002/220V/50Hz

6776 Valve, complete

Item	Description	Order No.	Quantity
1	Valve box	6429	1
2	Sealing bushing	6431	1
3	Valve piston	6418	1
4	Intermediate ring	6419	1
5	Disk	6343	1
6	O-ring	12237	1
7	O-ring	12236	1
8	O-ring	11005	1
9	Pressure spring	6432	1

1. Connection block

- 1.1 Exchange electromagnet, Item 7, Order No. 11002.
- 1.2 Unscrew four screws, Item 9.
- 1.3 Exchange electromagnet, Item 7.
- 1.4 Observe Item 4.7 c to e of the Repair Instructions, Subassemblies during assembly.

2. Valve

- 2.1 Exchange O-ring, Item 8, Order No. 11005.
- 2.2 Unscrew valve box, Item 1, SW 32, out of seal bushing, Item 2, SW 24.

ATTENTION: Parts are under spring tension!

- 2.3 Exchange O-ring, Item 8.

4296 Electric motor

Item	Description	220 V Order No.	110V Order No.	Quantity
501	Carbon brushes (set)	2899	2899	1
502	Armature	4301	430151	1
506	Carbon-brush holder	11707	11707	2
507	Capacitor	12036	11584	1
508	Noise suppression throttle	12037	12256	1
512	Clamping box compl.	11902	11902	1
513	Protecting cap	12133	12133	1
514	Terminal board	11516	11516	1
515	Ball bearing below	11735	11735	1
516	Ball bearing above	11736	11736	1

4296 Electric motor

1. Exchange set (2 each) of carbon brushes, Item 501, Order No. 2899.

- 1.1 Remove protection cap, Item 513.
- 1.2 Unscrew carbon brushes, Item 501, from carbon brush holder, Item 506.
- 1.3 Exchange carbon brush, Item 501.

2. Exchange armature, Item 502, Order No. 4301.

- 2.1 Loosen cable from terminal board, Item 514.
- 2.2 Remove protecting cap, Item 513.
- 2.3 Remove cap piece of the bearing C and shaft-locking ring.
- 2.4 Loosen four screws D and expel armature, Item 502, from the collector side.
- 2.5 Expel armature, Item 502, out of cap piece of the bearing B.
- 2.6 Exchange armature, Item 502.

3. Exchange bearing, Item 516, Order No. 11736.

- 3.1 Proceed as described under Item 2.1 to 2.4.
- 3.2 Expel bearing, Item 516, out of cap piece A of the bearing
- 3.3 Exchange bearing, Item 516.

4. Exchange bearing, Item 515, Order No. 11735.

- 4.1 Proceed as described under the Item 2.1 to 2.5.
- 4.2 Pull bearing, Item 515, off the lever staff.
- 4.3 Exchange bearing, Item 515.

E. SPARE PARTS LISTS, SINGLE PARTS**11020 Foot switch complete** (HA1 to pack No. 5608; HA2 to pack No. 569)

Item	Description	Order No.	Quantity
1	Cast-iron case	11839	1
2	Sealing washer	11840	1
3	Cover	11841	1
4	Pressure spring	11842	1
5	Press button	11843	1
6	Locking ring	11844	1
7	Housing base	11845	1
8	Circuit element	11699	1
9	Socket head screw	11847	2
10	Fillister head	11848	2
11	Washer	11231	1
12	Threaded screw	11850	1
13	Serrated lock washer	12109	1
14	Seal cable screw connection	11012	2
15	Cable bracket	11022	2

9186 Foot-/Emergency-stop-switch (HA1 from pack No. 5609; HA2 from pack No. 570)

Item	Description	Order No.	Quantity
1	Cable	12558	1
2	Foot switch complete	13311	1
3	Spring washer A5	11038	2
4	Socket head screw M 5x12	11039	2
5	Cable	13266	1
6	Emergency-stop-switch complete	8995	1
7	Spring washer A4	11360	2
8	Socket head screw M 4x8	11184	2
9	Connecting cable conf.	4297	1
10	Protection bow	8964	1

13311 Foot switch complete (HA1 from pack No. 5609; HA2 from pack No. 570)

Item	Description	Order No.	Quantity
1	Cast-iron case	11839	1
2	Gasket washer	11840	1
3	Cover	11841	1
4	Spring	11842	1
5	Push botton	11843	1
6	Outer circlip	11844	1
7	Housing (Base set)	11845	1
8	Switching element	11699	1
9	Socket head screw	11847	2
10	Fillister head screw	11848	2
11	Washer	11231	1
12	Threaded screw	11850	1
13	Serrated lock washer	12109	1
14	Seal-cable screw connection	11012	1
15	Cable bracket	11022	2
16	UNI-Seal-cable screw connection	13298	1

8995 Emergency-stop-switch complete (HA1 from pack No. 5609; HA2 from pack No. 570)

Item	Description	Order No.	Quantity
1	Emergency-stop-switch	13310	1
2	Cable screw connention PG16	12009	1
3	Cable screw connention	13309	1
4	Nut PG 16	12010	2

13310 Emergency-stop-switch (HA1 from pack No. 5609; HA2 from pack No. 570)

Item	Description	Order No.	Quantity
1	Housing	12000	1
2	Fastening adapter	11999	1
3	Contact element	12001	2
4	Emergency-stop-switch	12002	1

1956 Grip

Item	Description	Order No.	Quantity
1	Pressure pin	1951	1
2	Bush	1933	1
3	Sleeve	1370	1
4	Manuel pushbutton	31197	1
5	Screwing	11511	1
6	Cable	11512	1
7	Coupling sleeve	3719	1
8	Hydraulic hose	11513	1
9	Cable tape	11778	18
10	Dust cap	1515	1

**13
02**

**Su
cti
on
Sie
ve**

Item De
ser
ipti
on

1 B
anj
o
bel
t
2 D
isk
4 D
isk
5 S
iev
e
dis
k

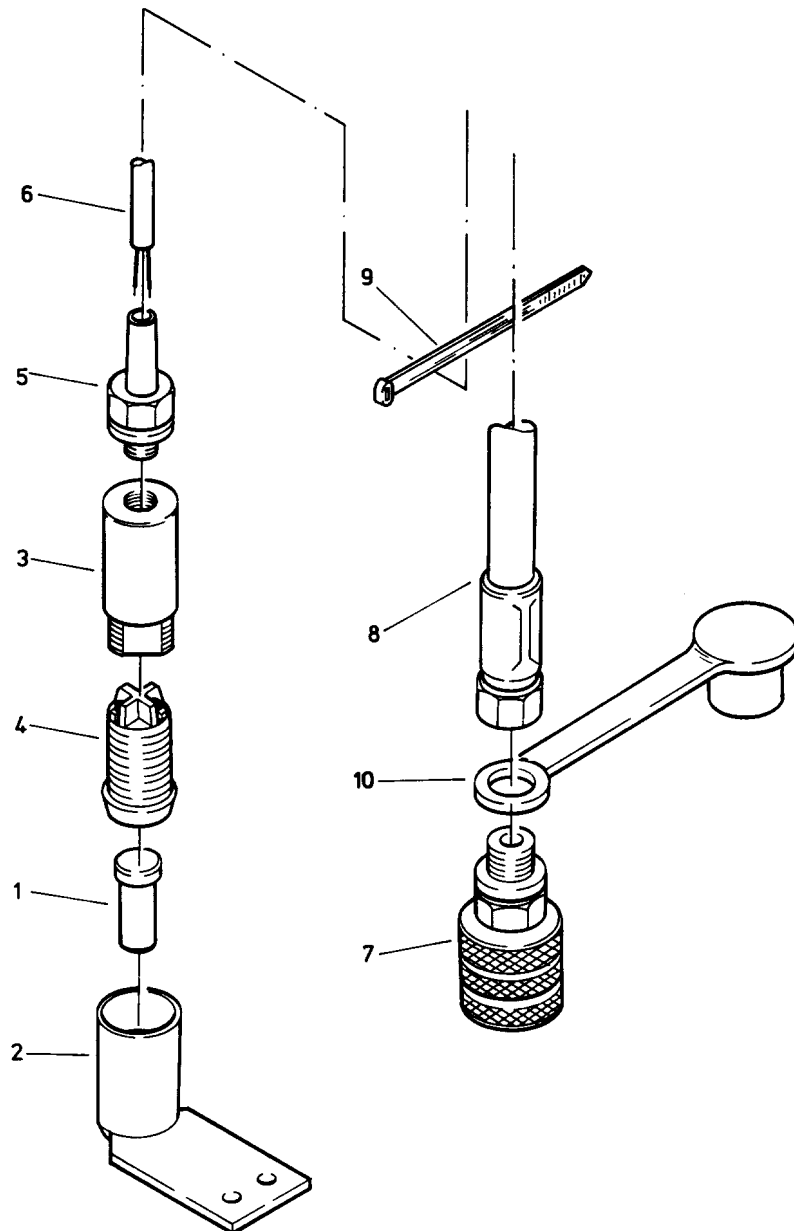

1532 Vent Valve HA

Item Description

- 1 Screws
- 2 End cap
- 3 Filter
- 4 Shim ring
- 5 Locking ring
- 6 O-ring
- 7 O-ring
- 8 Snap ring

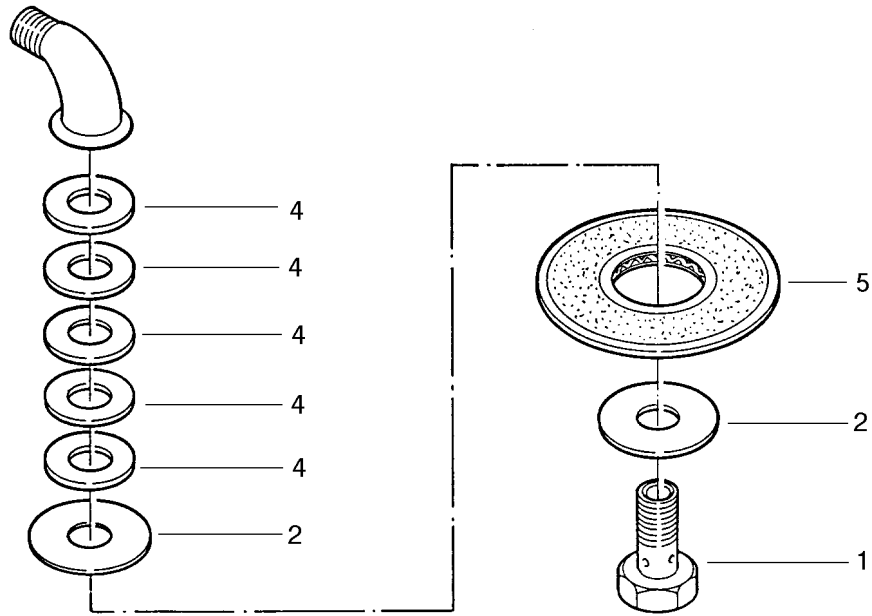

11029

11030	1
11007	1
11033	1
11031	1

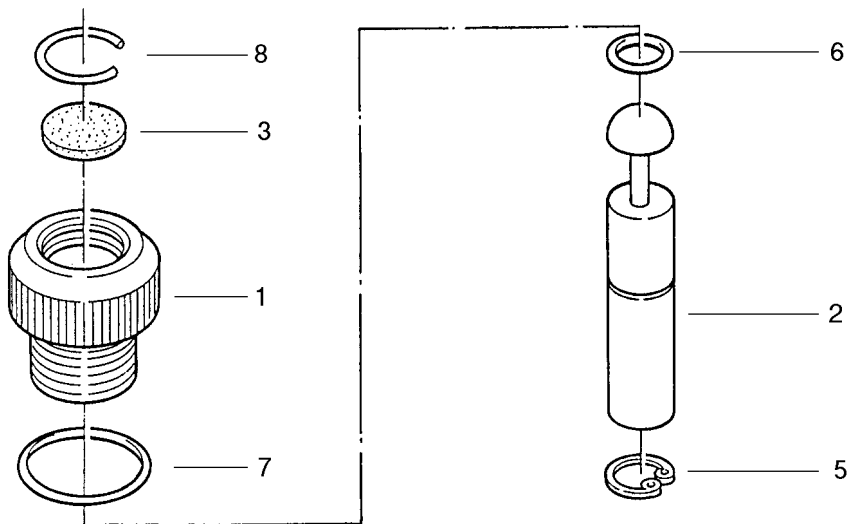

1709 Coupling

Item	Description	Order No.	Quantity
1	Gearwheel 1	1609	1
2	Gearwheel 2	1610	1
3	Sleeve	1611	1

1648 Packing set for hose coupling HA

Item	Description	Order No.	Quantity
1	O-ring	12097	1
2	Back-ring	12098	1

O-ring Back-ring Insert O-ring

Push back-ring all the way
round with blunt object up to
the installation

Repairs / Service

novopress

Scharnhorststraße 1
D-41460 Neuss

Postfach 101163
D-41411 Neuss

Telex 8 518 015

Tel. 02131 / 288-0

Federal Republic of Germany Telefax 02131 / 28855

Coupling sleeve Foot switch

Vent valve

Only screw in the valve screw by hand, never with a tool,
as otherwise the thread will rip in the lid.

Vent Valve

Only screw in the valve screw by hand, never with a tool,
as otherwise the thread will rip in the lid.

Coupling sleeve Hand switch Terminal block on the tool

coupling sleeve sliding sleeve coupling plug

Push back-ring all the way round with blunt objekt up to the installation

insert o-ring o-ring back-ring

see: list of parts 4200 item 43

list of parts 4350 item 35

